

FPM-5171G

17" SXGA Industrial Monitor with Resistive Touchscreen, Direct-VGA, and DVI Ports

NEW



Features

- 17" SXGA TFT LCD with resolution up to 1280 x 1024
- Direct VGA & DVI-D video input interface
- Lockable OSD keys with 2 user-defined contrast/brightness settings
- The flat-sealed front panel design
- Robust design with anti-rust chassis and aluminum die-cast front panel
- Front access USB connector
- Combo RS-232 & USB interface for touchscreen function (optional)
- Supports industrial 10-30 V_{DC} power input
- Supports Panel, Wall, Desktop, Rack or VESA arm mounting
- Front Panel NEMA4/IP65 Compliant

Introduction

FPM-5171G is a 17-inch color TFT LCD flat panel monitor specifically designed for industrial applications. With a viewing size as large as 17", it presents an ample display area as well as vivid and sharp images for your HMI. It features Direct-VGA & DVI-D signal transmission, which allows VGA control card to be used in your system. The onscreen display function also allows users to adjust the images on the screen with two user's setting. The front access USB connector, let user easy to access the controller. The industrial 10-30Vdc wild ranger power source support for best Factory automation and Machine automation display solution.

Specifications

General

- **Button Controls** OSD control pad on rear side with lockable function
- **Certification** BSMI, CCC, CE, FCC, UL
- **Dimension (W x H x D)** 481.9 x 355.9 x 58.5 mm (18.9" x 14" x 2.3")
- **Enclosure** Front panel: Aluminum with Flat-Sealed
Rear cover: antirust coating Chassis
- **Mounting** Panel, wall, desktop, VESA arm, or 19" rackmount
- **Power Input** Phoenix Jack - 10 ~ 30 V_{DC} input
Din Jack - External 50 W power adapter, with AC 100 V ~ 240 V input and DC +12 V @ 4.16 A output
- **USB** Front USB access for extension
- **Video Port** VGA & DVI-D
- **Weight (Net)** 8 kg

LCD Display

- **Display Type** SXGA TFT LCD
- **Display Size** 17"
- **Max. Resolution** 1280 x 1024
- **Max. Color** 16.7M
- **Viewing Angle (H, V)°** 160, 160
- **Luminance (cd/m²)** 300
- **Backlight Life (hrs)** 50,000
- **Contrast Ratio** 800 : 1

Touchscreen (Optional)

- **Type** 8-wire Resistive
- **Interface** RS-232 & USB
- **Lifespan** 10 million with a silicone rubber of R8 finger, writing rate is by 250g at 2 times/s
- **Light Transmission** > 80%
- **OS Support** Windows® 95/98/ME/2000/XP/CE/NT/Vista, Linux
- **Power Consumption** +5 V @ 100 mA
- **Touch Resolution** Linearity

Environment

- **Operation Temperature** 0 ~ 50° C (32 ~ 122° F)
- **Storage Temperature** -20 ~ 60° C (-4 ~ 140° F)
- **Humidity (Storage)** 10 ~ 95% non-condensing
- **Waterproof** Front Panel NEMA4/IP65 Compliant
- **Vibration** 5 ~ 500 Hz, 1 Grms (Operating, Random)

Ordering Information

- **FPM-5171G-X0AE** 17" Industrial Monitor with D-VGA & DVI-D ports
- **FPM-5171G-R3AE** 17" Industrial Monitor with D-VGA & DVI-D ports, Resistive Touchscreen RS-232 & USB Interface

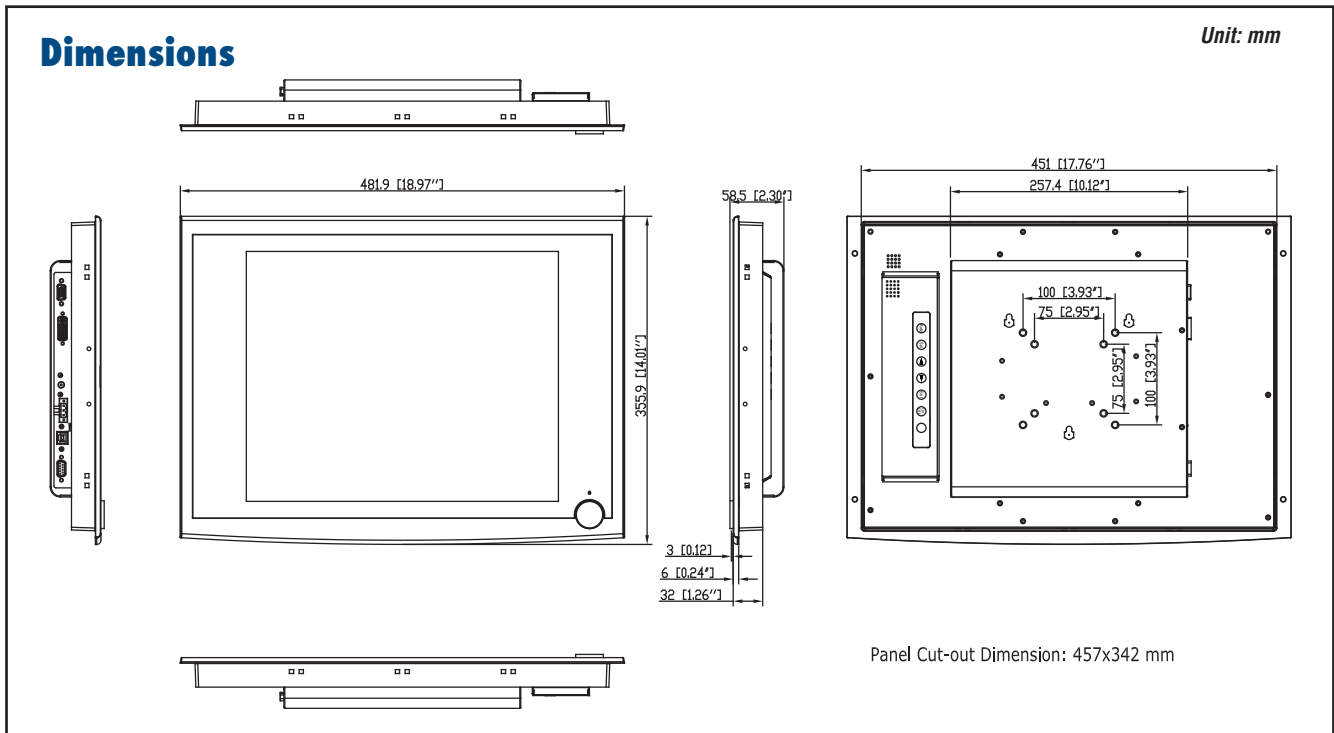

Accessories

- **FPM-5151G-SMKE** FPM-5151G/5171G Stand Kit
- **IPPC-6172A-RMKE** IPPC-6172A/FPM-5171G Rack Mount Kit
- **1702002600** Power Cable US Plug 1.8 M
- **1702002605** Power Cable EU Plug 1.8 M
- **1702031801** Power Cable UK Plug 1.8 M
- **1702031836** Power Cable China/Australia Plug 1.8 M

I/O View

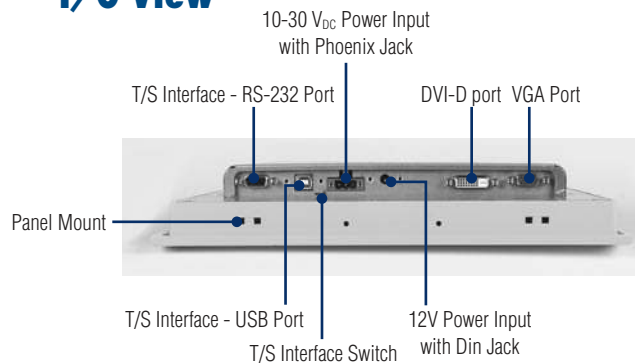

Front Access USB Port



Back View

